

TITUS™ ER14250M

Spiral Construction Size ½ AA

Scope:

This data sheet describes the mechanical design and electrical performance of the TITUS™ ER14250M, ½ AA-size, 3.6V, 0.75Ah, Primary Lithium Thionyl chloride (SOCl₂), HIGH POWER battery.

Mechanical / Physical Characteristics:

- Length
- Diameter
- Weight
- Lithium weight

0.99" max (25.2mm)
0.57" max (14.5mm)
11g max
~0.25g

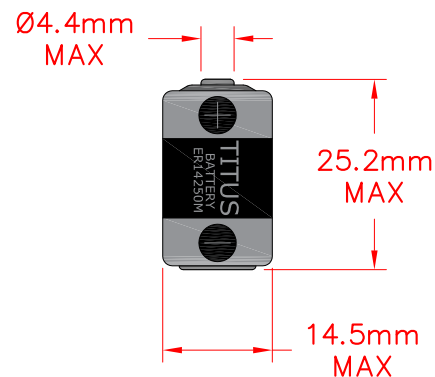

Electrical Characteristics:

- Nominal voltage
- Nominal capacity
- Maximum continuous discharge current
- Maximum pulse current
- Operating temperature

3.6V
0.75Ah
120mA
250mA
-55°C to +85°C

Standard Termination

Discharge Characteristics at 23±2°C

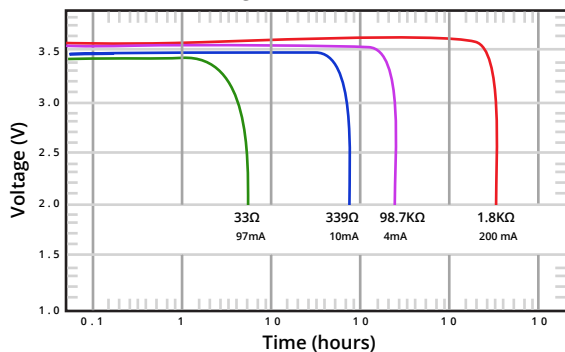

Capacity VS. Current

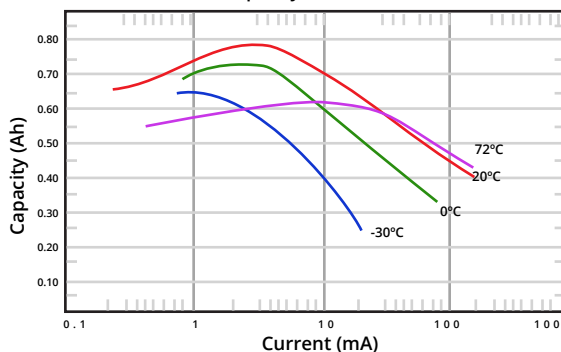

Voltage VS. Temperature

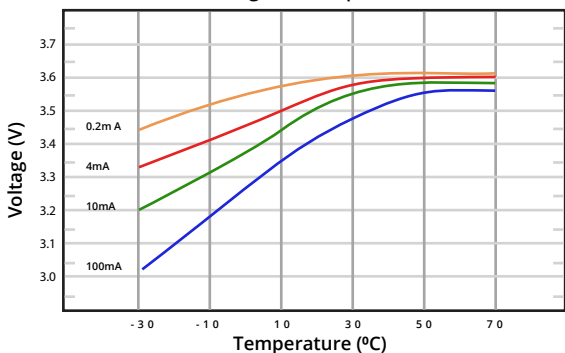

WARNING: Fire, explosion, and severe burn hazards.

- Do not disassemble
- Do not heat above 100°C
- Do not recharge, short circuit, crush, incinerate, or expose contents to water

Available Terminations:

S-Standard Termination T-Solder Tabs P-Axial Pins
Special terminations available upon request

Devon Company

680 Main St- Suite 206
Watertown, CT 06795
Tel: 8609451177

Email: info@devon-company.com
www.devon-company.com